

ACOUSTEEL DAMP 200

Anti-vibration

DIMENSIONS

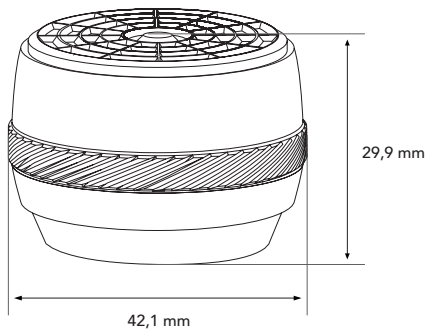

MAX LOAD



PRODUCT CODE

- **Finish :** Brass sand-nickel plated
- EAN :** 3700795180990
- SKU :** NORACODAMP200

DESCRIPTION

Optimize the sound experience of your audio system, the Acousteel Damp 200 is the ultimate solution for the most demanding audiophiles seeking greater clarity and sonic openness.

Thanks to its advanced vibration absorption system, the Acousteel Damp 200 neutralizes unwanted resonances by isolating vibrations that affect audio components.

DESIGN

Finish : *Brass sand-nickel plated*
Structure : *Brass with silicon rubber*

MAXIMUM LOAD

With 4 units : 80 kg max

USABLE DIMENSIONS

Diameter : 42,1 mm
Height : 29,9 mm

CONDITIONNEMENT

Delivered in units of 4
Dimensions (W x H x D) : 173 x 50 x 173 mm
Net Weight (elements) : 424 g
Gross Weight : 655 g

